

Exercise 5: Tree width and Hypertree width

Database Theory

2023-05-09

Maximilian Marx, Markus Krötzsch

Exercise 1

Exercise. Construct the query hypergraph and the primal graph for the following queries:

1. $\exists x, y, z, u, v. (r(x, y, z, u) \wedge s(z, u, v))$
2. $\exists x, y, z, u, v. (a(x, y) \wedge b(y, z) \wedge c(z, u) \wedge d(u, v) \wedge e(v, z) \wedge f(z, x) \wedge d(x, u) \wedge d(u, y))$

Exercise 1

Exercise. Construct the query hypergraph and the primal graph for the following queries:

1. $\exists x, y, z, u, v. (r(x, y, z, u) \wedge s(z, u, v))$
2. $\exists x, y, z, u, v. (a(x, y) \wedge b(y, z) \wedge c(z, u) \wedge d(u, v) \wedge e(v, z) \wedge f(z, x) \wedge d(x, u) \wedge d(u, y))$

Definition (Lecture 6, Slide 23)

The *primal graph* of a hypergraph G is the undirected graph with the same vertices as G , and an edge connecting two vertices if there is some hyperedge in G that contains these two vertices.

Exercise 1

Exercise. Construct the query hypergraph and the primal graph for the following queries:

1. $\exists x, y, z, u, v. (r(x, y, z, u) \wedge s(z, u, v))$
2. $\exists x, y, z, u, v. (a(x, y) \wedge b(y, z) \wedge c(z, u) \wedge d(u, v) \wedge e(v, z) \wedge f(z, x) \wedge d(x, u) \wedge d(u, y))$

Definition (Lecture 6, Slide 23)

The *primal graph* of a hypergraph G is the undirected graph with the same vertices as G , and an edge connecting two vertices if there is some hyperedge in G that contains these two vertices.

Solution.

Exercise 1

Exercise. Construct the query hypergraph and the primal graph for the following queries:

1. $\exists x, y, z, u, v. (r(x, y, z, u) \wedge s(z, u, v))$
2. $\exists x, y, z, u, v. (a(x, y) \wedge b(y, z) \wedge c(z, u) \wedge d(u, v) \wedge e(v, z) \wedge f(z, x) \wedge d(x, u) \wedge d(u, y))$

Definition (Lecture 6, Slide 23)

The *primal graph* of a hypergraph G is the undirected graph with the same vertices as G , and an edge connecting two vertices if there is some hyperedge in G that contains these two vertices.

Solution.

1.

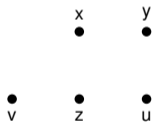

Exercise 1

Exercise. Construct the query hypergraph and the primal graph for the following queries:

1. $\exists x, y, z, u, v. (r(x, y, z, u) \wedge s(z, u, v))$
2. $\exists x, y, z, u, v. (a(x, y) \wedge b(y, z) \wedge c(z, u) \wedge d(u, v) \wedge e(v, z) \wedge f(z, x) \wedge d(x, u) \wedge d(u, y))$

Definition (Lecture 6, Slide 23)

The *primal graph* of a hypergraph G is the undirected graph with the same vertices as G , and an edge connecting two vertices if there is some hyperedge in G that contains these two vertices.

Solution.

1.

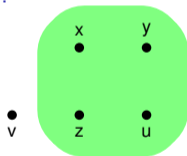

Exercise 1

Exercise. Construct the query hypergraph and the primal graph for the following queries:

1. $\exists x, y, z, u, v. (r(x, y, z, u) \wedge s(z, u, v))$
2. $\exists x, y, z, u, v. (a(x, y) \wedge b(y, z) \wedge c(z, u) \wedge d(u, v) \wedge e(v, z) \wedge f(z, x) \wedge d(x, u) \wedge d(u, y))$

Definition (Lecture 6, Slide 23)

The *primal graph* of a hypergraph G is the undirected graph with the same vertices as G , and an edge connecting two vertices if there is some hyperedge in G that contains these two vertices.

Solution.

1.

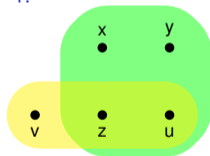

Exercise 1

Exercise. Construct the query hypergraph and the primal graph for the following queries:

1. $\exists x, y, z, u, v. (r(x, y, z, u) \wedge s(z, u, v))$
2. $\exists x, y, z, u, v. (a(x, y) \wedge b(y, z) \wedge c(z, u) \wedge d(u, v) \wedge e(v, z) \wedge f(z, x) \wedge d(x, u) \wedge d(u, y))$

Definition (Lecture 6, Slide 23)

The *primal graph* of a hypergraph G is the undirected graph with the same vertices as G , and an edge connecting two vertices if there is some hyperedge in G that contains these two vertices.

Solution.

1.

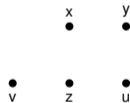
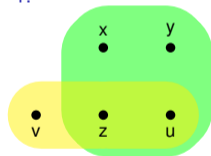

Exercise 1

Exercise. Construct the query hypergraph and the primal graph for the following queries:

1. $\exists x, y, z, u, v. (r(x, y, z, u) \wedge s(z, u, v))$
2. $\exists x, y, z, u, v. (a(x, y) \wedge b(y, z) \wedge c(z, u) \wedge d(u, v) \wedge e(v, z) \wedge f(z, x) \wedge d(x, u) \wedge d(u, y))$

Definition (Lecture 6, Slide 23)

The *primal graph* of a hypergraph G is the undirected graph with the same vertices as G , and an edge connecting two vertices if there is some hyperedge in G that contains these two vertices.

Solution.

1.

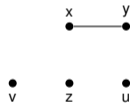
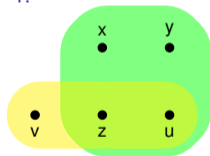

Exercise 1

Exercise. Construct the query hypergraph and the primal graph for the following queries:

1. $\exists x, y, z, u, v. (r(x, y, z, u) \wedge s(z, u, v))$
2. $\exists x, y, z, u, v. (a(x, y) \wedge b(y, z) \wedge c(z, u) \wedge d(u, v) \wedge e(v, z) \wedge f(z, x) \wedge d(x, u) \wedge d(u, y))$

Definition (Lecture 6, Slide 23)

The *primal graph* of a hypergraph G is the undirected graph with the same vertices as G , and an edge connecting two vertices if there is some hyperedge in G that contains these two vertices.

Solution.

1.

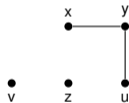
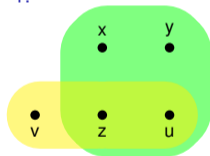

Exercise 1

Exercise. Construct the query hypergraph and the primal graph for the following queries:

1. $\exists x, y, z, u, v. (r(x, y, z, u) \wedge s(z, u, v))$
2. $\exists x, y, z, u, v. (a(x, y) \wedge b(y, z) \wedge c(z, u) \wedge d(u, v) \wedge e(v, z) \wedge f(z, x) \wedge d(x, u) \wedge d(u, y))$

Definition (Lecture 6, Slide 23)

The *primal graph* of a hypergraph G is the undirected graph with the same vertices as G , and an edge connecting two vertices if there is some hyperedge in G that contains these two vertices.

Solution.

1.

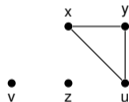
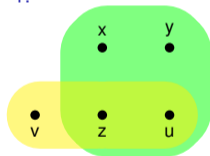

Exercise 1

Exercise. Construct the query hypergraph and the primal graph for the following queries:

1. $\exists x, y, z, u, v. (r(x, y, z, u) \wedge s(z, u, v))$
2. $\exists x, y, z, u, v. (a(x, y) \wedge b(y, z) \wedge c(z, u) \wedge d(u, v) \wedge e(v, z) \wedge f(z, x) \wedge d(x, u) \wedge d(u, y))$

Definition (Lecture 6, Slide 23)

The *primal graph* of a hypergraph G is the undirected graph with the same vertices as G , and an edge connecting two vertices if there is some hyperedge in G that contains these two vertices.

Solution.

1.

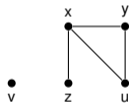
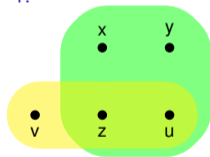

Exercise 1

Exercise. Construct the query hypergraph and the primal graph for the following queries:

1. $\exists x, y, z, u, v. (r(x, y, z, u) \wedge s(z, u, v))$
2. $\exists x, y, z, u, v. (a(x, y) \wedge b(y, z) \wedge c(z, u) \wedge d(u, v) \wedge e(v, z) \wedge f(z, x) \wedge d(x, u) \wedge d(u, y))$

Definition (Lecture 6, Slide 23)

The *primal graph* of a hypergraph G is the undirected graph with the same vertices as G , and an edge connecting two vertices if there is some hyperedge in G that contains these two vertices.

Solution.

1.

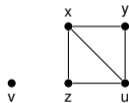
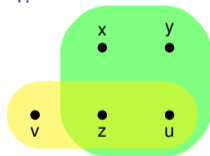

Exercise 1

Exercise. Construct the query hypergraph and the primal graph for the following queries:

1. $\exists x, y, z, u, v. (r(x, y, z, u) \wedge s(z, u, v))$
2. $\exists x, y, z, u, v. (a(x, y) \wedge b(y, z) \wedge c(z, u) \wedge d(u, v) \wedge e(v, z) \wedge f(z, x) \wedge d(x, u) \wedge d(u, y))$

Definition (Lecture 6, Slide 23)

The *primal graph* of a hypergraph G is the undirected graph with the same vertices as G , and an edge connecting two vertices if there is some hyperedge in G that contains these two vertices.

Solution.

1.

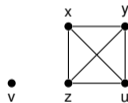
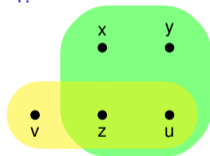

Exercise 1

Exercise. Construct the query hypergraph and the primal graph for the following queries:

1. $\exists x, y, z, u, v. (r(x, y, z, u) \wedge s(z, u, v))$
2. $\exists x, y, z, u, v. (a(x, y) \wedge b(y, z) \wedge c(z, u) \wedge d(u, v) \wedge e(v, z) \wedge f(z, x) \wedge d(x, u) \wedge d(u, y))$

Definition (Lecture 6, Slide 23)

The *primal graph* of a hypergraph G is the undirected graph with the same vertices as G , and an edge connecting two vertices if there is some hyperedge in G that contains these two vertices.

Solution.

1.

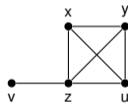
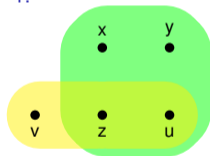

Exercise 1

Exercise. Construct the query hypergraph and the primal graph for the following queries:

1. $\exists x, y, z, u, v. (r(x, y, z, u) \wedge s(z, u, v))$
2. $\exists x, y, z, u, v. (a(x, y) \wedge b(y, z) \wedge c(z, u) \wedge d(u, v) \wedge e(v, z) \wedge f(z, x) \wedge d(x, u) \wedge d(u, y))$

Definition (Lecture 6, Slide 23)

The *primal graph* of a hypergraph G is the undirected graph with the same vertices as G , and an edge connecting two vertices if there is some hyperedge in G that contains these two vertices.

Solution.

1.

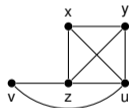
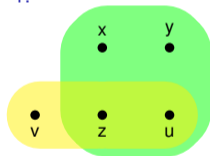

Exercise 1

Exercise. Construct the query hypergraph and the primal graph for the following queries:

1. $\exists x, y, z, u, v. (r(x, y, z, u) \wedge s(z, u, v))$
2. $\exists x, y, z, u, v. (a(x, y) \wedge b(y, z) \wedge c(z, u) \wedge d(u, v) \wedge e(v, z) \wedge f(z, x) \wedge d(x, u) \wedge d(u, y))$

Definition (Lecture 6, Slide 23)

The *primal graph* of a hypergraph G is the undirected graph with the same vertices as G , and an edge connecting two vertices if there is some hyperedge in G that contains these two vertices.

Solution.

1.

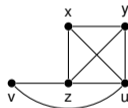
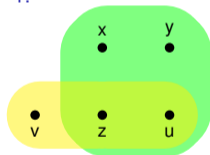

2.

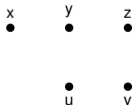

Exercise 1

Exercise. Construct the query hypergraph and the primal graph for the following queries:

1. $\exists x, y, z, u, v. (r(x, y, z, u) \wedge s(z, u, v))$
2. $\exists x, y, z, u, v. (a(x, y) \wedge b(y, z) \wedge c(z, u) \wedge d(u, v) \wedge e(v, z) \wedge f(z, x) \wedge d(x, u) \wedge d(u, y))$

Definition (Lecture 6, Slide 23)

The *primal graph* of a hypergraph G is the undirected graph with the same vertices as G , and an edge connecting two vertices if there is some hyperedge in G that contains these two vertices.

Solution.

1.

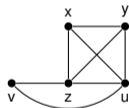
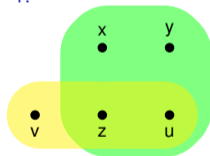

2.

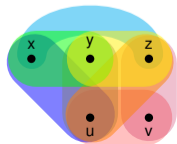

Exercise 1

Exercise. Construct the query hypergraph and the primal graph for the following queries:

1. $\exists x, y, z, u, v. (r(x, y, z, u) \wedge s(z, u, v))$
2. $\exists x, y, z, u, v. (a(x, y) \wedge b(y, z) \wedge c(z, u) \wedge d(u, v) \wedge e(v, z) \wedge f(z, x) \wedge d(x, u) \wedge d(u, y))$

Definition (Lecture 6, Slide 23)

The *primal graph* of a hypergraph G is the undirected graph with the same vertices as G , and an edge connecting two vertices if there is some hyperedge in G that contains these two vertices.

Solution.

1.

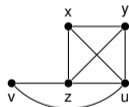
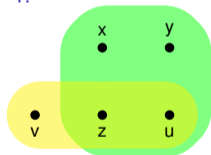

2.

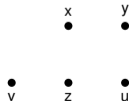
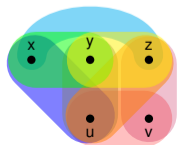

Exercise 1

Exercise. Construct the query hypergraph and the primal graph for the following queries:

1. $\exists x, y, z, u, v. (r(x, y, z, u) \wedge s(z, u, v))$
2. $\exists x, y, z, u, v. (a(x, y) \wedge b(y, z) \wedge c(z, u) \wedge d(u, v) \wedge e(v, z) \wedge f(z, x) \wedge d(x, u) \wedge d(u, y))$

Definition (Lecture 6, Slide 23)

The *primal graph* of a hypergraph G is the undirected graph with the same vertices as G , and an edge connecting two vertices if there is some hyperedge in G that contains these two vertices.

Solution.

1.

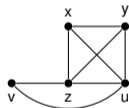
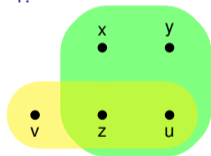

2.

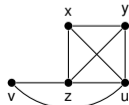
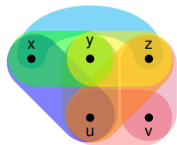

Exercise 2

Exercise. Determine the tree width of each of the following graphs and provide a suitable tree decomposition. Argue why there cannot be a tree decomposition of smaller width.

1.



2.

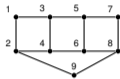

3.

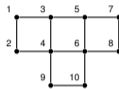

4.

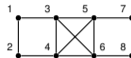

Exercise 2

Exercise. Determine the tree width of each of the following graphs and provide a suitable tree decomposition. Argue why there cannot be a tree decomposition of smaller width.

1.



Solution.

2.

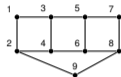

3.

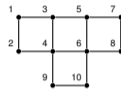

4.

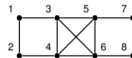

Exercise 2

Exercise. Determine the tree width of each of the following graphs and provide a suitable tree decomposition. Argue why there cannot be a tree decomposition of smaller width.

1.



Solution.

1.

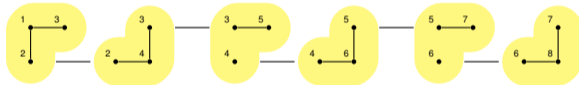

2.

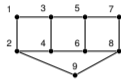

3.

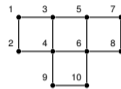

4.

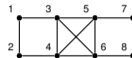

Exercise 2

Exercise. Determine the tree width of each of the following graphs and provide a suitable tree decomposition. Argue why there cannot be a tree decomposition of smaller width.

1.



Solution.

1.

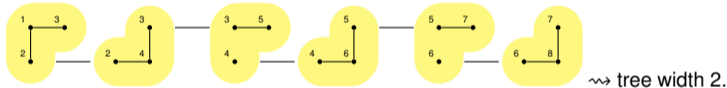

2.

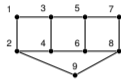

3.

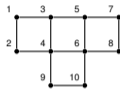

4.

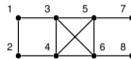

Exercise 2

Exercise. Determine the tree width of each of the following graphs and provide a suitable tree decomposition. Argue why there cannot be a tree decomposition of smaller width.

1.



Solution.

1.

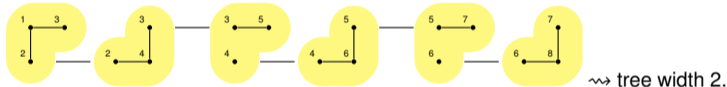

2.

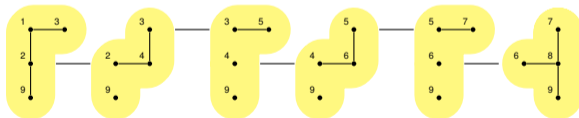

2.

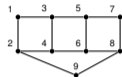

3.

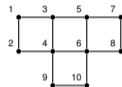

4.

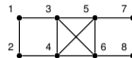

Exercise 2

Exercise. Determine the tree width of each of the following graphs and provide a suitable tree decomposition. Argue why there cannot be a tree decomposition of smaller width.

1.



Solution.

1.

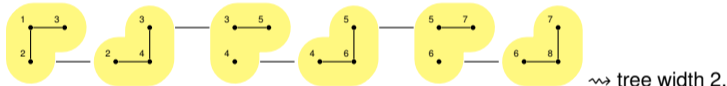

2.

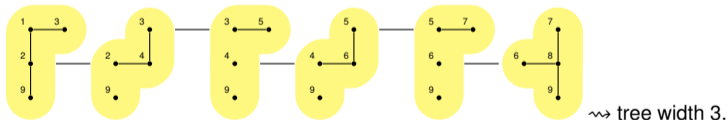

2.

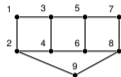

3.

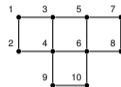

4.

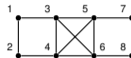

Exercise 2

Exercise. Determine the tree width of each of the following graphs and provide a suitable tree decomposition. Argue why there cannot be a tree decomposition of smaller width.

1.



Solution.

3.

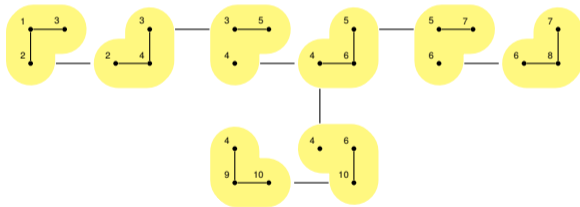

2.

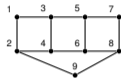

3.

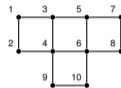

4.

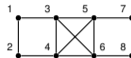

Exercise 2

Exercise. Determine the tree width of each of the following graphs and provide a suitable tree decomposition. Argue why there cannot be a tree decomposition of smaller width.

1.



Solution.

3.

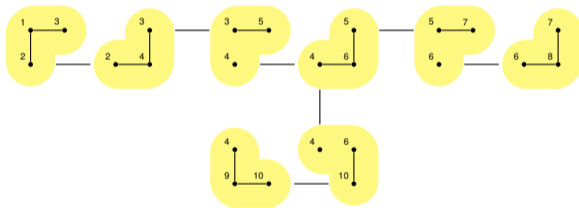

\rightsquigarrow tree width 2.

2.

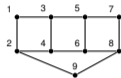

3.

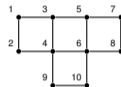

4.

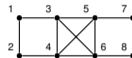

Exercise 2

Exercise. Determine the tree width of each of the following graphs and provide a suitable tree decomposition. Argue why there cannot be a tree decomposition of smaller width.

1.



Solution.

3.

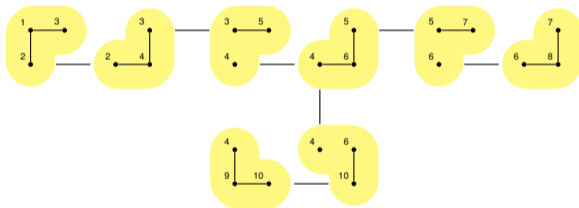

≈ tree width 2.

2.

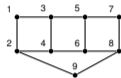

3.

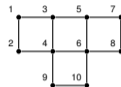

4.

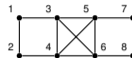

4.

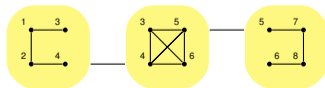

Exercise 2

Exercise. Determine the tree width of each of the following graphs and provide a suitable tree decomposition. Argue why there cannot be a tree decomposition of smaller width.

1.



Solution.

3.

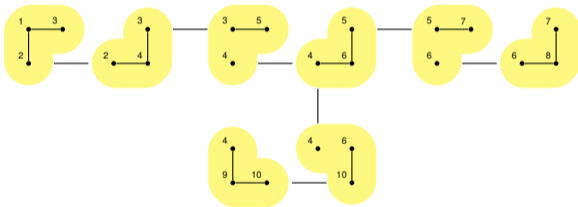

≈ tree width 2.

4.

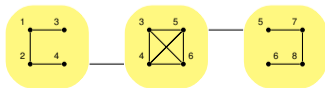

≈ tree width 3.

2.

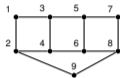

3.

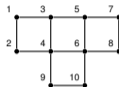

4.

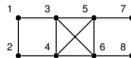

Exercise 3

Exercise. Show that the $n \times n$ grid has a tree width $\leq n$ by finding a suitable tree decomposition of width n . For example, the following 4×4 grid has tree width 4:

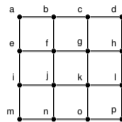

Exercise 3

Exercise. Show that the $n \times n$ grid has a tree width $\leq n$ by finding a suitable tree decomposition of width n . For example, the following 4×4 grid has tree width 4:

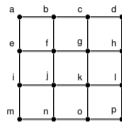

Solution.

Exercise 3

Exercise. Show that the $n \times n$ grid has a tree width $\leq n$ by finding a suitable tree decomposition of width n . For example, the following 4×4 grid has tree width 4:

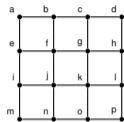

Solution.

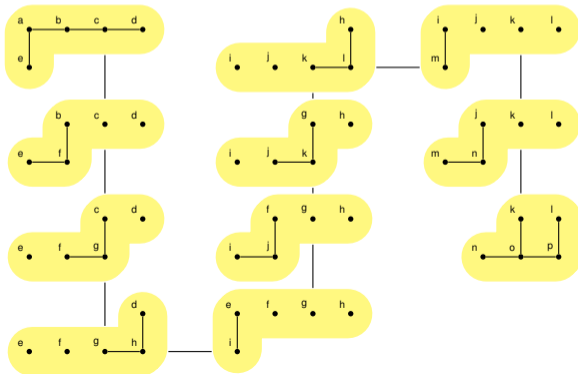

Exercise 4

Exercise. Show that a clique (fully connected graph) of size n has tree width $n - 1$.

Exercise 4

Exercise. Show that a clique (fully connected graph) of size n has tree width $n - 1$.

Theorem (Seymour and Thomas; Lecture 7, Slide 15)

A graph G is of tree width $\leq k - 1$ iff k cops have a winning strategy in the cops & robber game on G .

Exercise 4

Exercise. Show that a clique (fully connected graph) of size n has tree width $n - 1$.

Theorem (Seymour and Thomas; Lecture 7, Slide 15)

A graph G is of tree width $\leq k - 1$ iff k cops have a winning strategy in the cops & robber game on G .

Solution.

Exercise 4

Exercise. Show that a clique (fully connected graph) of size n has tree width $n - 1$.

Theorem (Seymour and Thomas; Lecture 7, Slide 15)

A graph G is of tree width $\leq k - 1$ iff k cops have a winning strategy in the cops & robber game on G .

Solution.

- ▶ Consider an n -clique.

Exercise 4

Exercise. Show that a clique (fully connected graph) of size n has tree width $n - 1$.

Theorem (Seymour and Thomas; Lecture 7, Slide 15)

A graph G is of tree width $\leq k - 1$ iff k cops have a winning strategy in the cops & robber game on G .

Solution.

- ▶ Consider an n -clique.
- ▶ Clearly, n cops have a winning strategy: they can occupy every vertex.

Exercise 4

Exercise. Show that a clique (fully connected graph) of size n has tree width $n - 1$.

Theorem (Seymour and Thomas; Lecture 7, Slide 15)

A graph G is of tree width $\leq k - 1$ iff k cops have a winning strategy in the cops & robber game on G .

Solution.

- ▶ Consider an n -clique.
- ▶ Clearly, n cops have a winning strategy: they can occupy every vertex.
- ▶ Thus, an n -clique has tree width at most $n - 1$.

Exercise 4

Exercise. Show that a clique (fully connected graph) of size n has tree width $n - 1$.

Theorem (Seymour and Thomas; Lecture 7, Slide 15)

A graph G is of tree width $\leq k - 1$ iff k cops have a winning strategy in the cops & robber game on G .

Solution.

- ▶ Consider an n -clique.
- ▶ Clearly, n cops have a winning strategy: they can occupy every vertex.
- ▶ Thus, an n -clique has tree width at most $n - 1$.
- ▶ Consider the cops & robber game with $n - 1$ cops.

Exercise 4

Exercise. Show that a clique (fully connected graph) of size n has tree width $n - 1$.

Theorem (Seymour and Thomas; Lecture 7, Slide 15)

A graph G is of tree width $\leq k - 1$ iff k cops have a winning strategy in the cops & robber game on G .

Solution.

- ▶ Consider an n -clique.
- ▶ Clearly, n cops have a winning strategy: they can occupy every vertex.
- ▶ Thus, an n -clique has tree width at most $n - 1$.
- ▶ Consider the cops & robber game with $n - 1$ cops.
- ▶ Every vertex has $n - 1$ neighbours.

Exercise 4

Exercise. Show that a clique (fully connected graph) of size n has tree width $n - 1$.

Theorem (Seymour and Thomas; Lecture 7, Slide 15)

A graph G is of tree width $\leq k - 1$ iff k cops have a winning strategy in the cops & robber game on G .

Solution.

- ▶ Consider an n -clique.
- ▶ Clearly, n cops have a winning strategy: they can occupy every vertex.
- ▶ Thus, an n -clique has tree width at most $n - 1$.
- ▶ Consider the cops & robber game with $n - 1$ cops.
- ▶ Every vertex has $n - 1$ neighbours.
- ▶ While the cops can occupy all neighbouring vertices, they cannot catch the robber: if they move to the robbers position, one of the neighbouring vertices becomes free.

Exercise 4

Exercise. Show that a clique (fully connected graph) of size n has tree width $n - 1$.

Theorem (Seymour and Thomas; Lecture 7, Slide 15)

A graph G is of tree width $\leq k - 1$ iff k cops have a winning strategy in the cops & robber game on G .

Solution.

- ▶ Consider an n -clique.
- ▶ Clearly, n cops have a winning strategy: they can occupy every vertex.
- ▶ Thus, an n -clique has tree width at most $n - 1$.
- ▶ Consider the cops & robber game with $n - 1$ cops.
- ▶ Every vertex has $n - 1$ neighbours.
- ▶ While the cops can occupy all neighbouring vertices, they cannot catch the robber: if they move to the robbers position, one of the neighbouring vertices becomes free.
- ▶ Thus, the robber wins if there are at most $n - 1$ cops.

Exercise 4

Exercise. Show that a clique (fully connected graph) of size n has tree width $n - 1$.

Theorem (Seymour and Thomas; Lecture 7, Slide 15)

A graph G is of tree width $\leq k - 1$ iff k cops have a winning strategy in the cops & robber game on G .

Solution.

- ▶ Consider an n -clique.
- ▶ Clearly, n cops have a winning strategy: they can occupy every vertex.
- ▶ Thus, an n -clique has tree width at most $n - 1$.
- ▶ Consider the cops & robber game with $n - 1$ cops.
- ▶ Every vertex has $n - 1$ neighbours.
- ▶ While the cops can occupy all neighbouring vertices, they cannot catch the robber: if they move to the robbers position, one of the neighbouring vertices becomes free.
- ▶ Thus, the robber wins if there are at most $n - 1$ cops.
- ▶ Hence the n -clique cannot have tree width $\leq n - 2$.

Exercise 5

Exercise. Recall that a graph is 3-colourable if one can assign three colours to its vertices in such a way that neighbouring vertices never share the same colour. Let C_3 be the set of all 3-colourable graphs. Are the graphs in C_3 of bounded or unbounded tree width? Explain your answer.

Exercise 5

Exercise. Recall that a graph is 3-colourable if one can assign three colours to its vertices in such a way that neighbouring vertices never share the same colour. Let C_3 be the set of all 3-colourable graphs. Are the graphs in C_3 of bounded or unbounded tree width? Explain your answer.

Solution.

Exercise 5

Exercise. Recall that a graph is 3-colourable if one can assign three colours to its vertices in such a way that neighbouring vertices never share the same colour. Let C_3 be the set of all 3-colourable graphs. Are the graphs in C_3 of bounded or unbounded tree width? Explain your answer.

Solution.

- ▶ Any $n \times n$ grid is 2-colourable.

Exercise 5

Exercise. Recall that a graph is 3-colourable if one can assign three colours to its vertices in such a way that neighbouring vertices never share the same colour. Let C_3 be the set of all 3-colourable graphs. Are the graphs in C_3 of bounded or unbounded tree width? Explain your answer.

Solution.

- ▶ Any $n \times n$ grid is 2-colourable.
- ▶ Hence, C_3 contains all grids.

Exercise 5

Exercise. Recall that a graph is 3-colourable if one can assign three colours to its vertices in such a way that neighbouring vertices never share the same colour. Let C_3 be the set of all 3-colourable graphs. Are the graphs in C_3 of bounded or unbounded tree width? Explain your answer.

Solution.

- ▶ Any $n \times n$ grid is 2-colourable.
- ▶ Hence, C_3 contains all grids.
- ▶ Grids have unbounded tree width.

Exercise 5

Exercise. Recall that a graph is 3-colourable if one can assign three colours to its vertices in such a way that neighbouring vertices never share the same colour. Let C_3 be the set of all 3-colourable graphs. Are the graphs in C_3 of bounded or unbounded tree width? Explain your answer.

Solution.

- ▶ Any $n \times n$ grid is 2-colourable.
- ▶ Hence, C_3 contains all grids.
- ▶ Grids have unbounded tree width.
- ▶ Thus, C_3 contains graphs of unbounded tree width.

Exercise 6

Exercise. Decide whether the following claims are true or false. Explain your answer.

1. Deleting an edge from a graph may make the tree width smaller but never larger.
2. Deleting a vertex from a graph (and removing all of its edges) may make the tree width smaller but never larger.
3. Deleting a hyperedge from a hypergraph may make the hypertree width smaller but never larger.
4. Deleting a vertex from a hypergraph (and removing empty edges) may make the hypertree width smaller but never larger.

Exercise 6

Exercise. Decide whether the following claims are true or false. Explain your answer.

1. Deleting an edge from a graph may make the tree width smaller but never larger.
2. Deleting a vertex from a graph (and removing all of its edges) may make the tree width smaller but never larger.
3. Deleting a hyperedge from a hypergraph may make the hypertree width smaller but never larger.
4. Deleting a vertex from a hypergraph (and removing empty edges) may make the hypertree width smaller but never larger.

Theorem (Seymour and Thomas; Lecture 7, Slide 15)

A graph G is of tree width $\leq k - 1$ iff k cops have a winning strategy in the cops & robber game on G .

Exercise 6

Exercise. Decide whether the following claims are true or false. Explain your answer.

1. Deleting an edge from a graph may make the tree width smaller but never larger.
2. Deleting a vertex from a graph (and removing all of its edges) may make the tree width smaller but never larger.
3. Deleting a hyperedge from a hypergraph may make the hypertree width smaller but never larger.
4. Deleting a vertex from a hypergraph (and removing empty edges) may make the hypertree width smaller but never larger.

Theorem (Seymour and Thomas; Lecture 7, Slide 15)

A graph G is of tree width $\leq k - 1$ iff k cops have a winning strategy in the cops & robber game on G .

Theorem (Lecture 8, Slide 17)

A hypergraph H is of hypertree width $\leq k$ iff k marshals have a winning strategy in the marshals & robber game on H .

Exercise 6

Exercise. Decide whether the following claims are true or false. Explain your answer.

1. Deleting an edge from a graph may make the tree width smaller but never larger.
2. Deleting a vertex from a graph (and removing all of its edges) may make the tree width smaller but never larger.
3. Deleting a hyperedge from a hypergraph may make the hypertree width smaller but never larger.
4. Deleting a vertex from a hypergraph (and removing empty edges) may make the hypertree width smaller but never larger.

Theorem (Seymour and Thomas; Lecture 7, Slide 15)

A graph G is of tree width $\leq k - 1$ iff k cops have a winning strategy in the cops & robber game on G .

Theorem (Lecture 8, Slide 17)

A hypergraph H is of hypertree width $\leq k$ iff k marshals have a winning strategy in the marshals & robber game on H .

Solution.

Exercise 6

Exercise. Decide whether the following claims are true or false. Explain your answer.

1. Deleting an edge from a graph may make the tree width smaller but never larger.
2. Deleting a vertex from a graph (and removing all of its edges) may make the tree width smaller but never larger.
3. Deleting a hyperedge from a hypergraph may make the hypertree width smaller but never larger.
4. Deleting a vertex from a hypergraph (and removing empty edges) may make the hypertree width smaller but never larger.

Theorem (Seymour and Thomas; Lecture 7, Slide 15)

A graph G is of tree width $\leq k - 1$ iff k cops have a winning strategy in the cops & robber game on G .

Theorem (Lecture 8, Slide 17)

A hypergraph H is of hypertree width $\leq k$ iff k marshals have a winning strategy in the marshals & robber game on H .

Solution.

1. True: cops don't walk along edges, so deleting edges does not invalidate winning strategies.

Exercise 6

Exercise. Decide whether the following claims are true or false. Explain your answer.

1. Deleting an edge from a graph may make the tree width smaller but never larger.
2. Deleting a vertex from a graph (and removing all of its edges) may make the tree width smaller but never larger.
3. Deleting a hyperedge from a hypergraph may make the hypertree width smaller but never larger.
4. Deleting a vertex from a hypergraph (and removing empty edges) may make the hypertree width smaller but never larger.

Theorem (Seymour and Thomas; Lecture 7, Slide 15)

A graph G is of tree width $\leq k - 1$ iff k cops have a winning strategy in the cops & robber game on G .

Theorem (Lecture 8, Slide 17)

A hypergraph H is of hypertree width $\leq k$ iff k marshals have a winning strategy in the marshals & robber game on H .

Solution.

1. True: cops don't walk along edges, so deleting edges does not invalidate winning strategies.
2. True: analogous.

Exercise 6

Exercise. Decide whether the following claims are true or false. Explain your answer.

1. Deleting an edge from a graph may make the tree width smaller but never larger.
2. Deleting a vertex from a graph (and removing all of its edges) may make the tree width smaller but never larger.
3. Deleting a hyperedge from a hypergraph may make the hypertree width smaller but never larger.
4. Deleting a vertex from a hypergraph (and removing empty edges) may make the hypertree width smaller but never larger.

Theorem (Seymour and Thomas; Lecture 7, Slide 15)

A graph G is of tree width $\leq k - 1$ iff k cops have a winning strategy in the cops & robber game on G .

Theorem (Lecture 8, Slide 17)

A hypergraph H is of hypertree width $\leq k$ iff k marshals have a winning strategy in the marshals & robber game on H .

Solution.

1. True: cops don't walk along edges, so deleting edges does not invalidate winning strategies.
2. True: analogous.
3. False: Consider a hypergraph that has a hyperedge containing all vertices. Then the hypergraph is acyclic (i.e., has hypertree width 1), but removing the hyperedge may result in a cyclic hypergraph (i.e., hypertree width > 1).

Exercise 6

Exercise. Decide whether the following claims are true or false. Explain your answer.

1. Deleting an edge from a graph may make the tree width smaller but never larger.
2. Deleting a vertex from a graph (and removing all of its edges) may make the tree width smaller but never larger.
3. Deleting a hyperedge from a hypergraph may make the hypertree width smaller but never larger.
4. Deleting a vertex from a hypergraph (and removing empty edges) may make the hypertree width smaller but never larger.

Theorem (Seymour and Thomas; Lecture 7, Slide 15)

A graph G is of tree width $\leq k - 1$ iff k cops have a winning strategy in the cops & robber game on G .

Theorem (Lecture 8, Slide 17)

A hypergraph H is of hypertree width $\leq k$ iff k marshals have a winning strategy in the marshals & robber game on H .

Solution.

1. True: cops don't walk along edges, so deleting edges does not invalidate winning strategies.
2. True: analogous.
3. False: Consider a hypergraph that has a hyperedge containing all vertices. Then the hypergraph is acyclic (i.e., has hypertree width 1), but removing the hyperedge may result in a cyclic hypergraph (i.e., hypertree width > 1).
4. True: marshals don't occupy vertices, but hyperedges, so deleting vertices does not invalidate winning strategies.

Exercise 7

Exercise. The following BCQ corresponds to graph (a) in Exercise 2:

$$\exists x_1, x_2, x_3, x_4, x_5, x_6, x_7, x_8. r(x_1, x_2) \wedge r(x_1, x_3) \wedge r(x_2, x_4) \wedge r(x_3, x_4) \wedge r(x_3, x_5) \wedge \\ r(x_4, x_6) \wedge r(x_5, x_6) \wedge r(x_5, x_7) \wedge r(x_6, x_8) \wedge r(x_7, x_8)$$

According to the logical characterisation from the lecture, this query can be expressed in the $\exists\text{-}\wedge$ -fragment of FO using only tree width+1 variables. Find such a formula.

Exercise 7

Exercise. The following BCQ corresponds to graph (a) in Exercise 2:

$$\exists x_1, x_2, x_3, x_4, x_5, x_6, x_7, x_8. r(x_1, x_2) \wedge r(x_1, x_3) \wedge r(x_2, x_4) \wedge r(x_3, x_4) \wedge r(x_3, x_5) \wedge \\ r(x_4, x_6) \wedge r(x_5, x_6) \wedge r(x_5, x_7) \wedge r(x_6, x_8) \wedge r(x_7, x_8)$$

According to the logical characterisation from the lecture, this query can be expressed in the \exists - \wedge -fragment of FO using only tree width+1 variables. Find such a formula.

Solution.

$$\exists x, y, z. r(x, y) \wedge r(x, z) \wedge \\ (\exists x. r(y, x) \wedge r(z, x) \wedge \\ (\exists y. r(z, y) \wedge \\ (\exists z. r(x, z) \wedge r(y, z) \wedge \\ (\exists x. r(y, x) \wedge \\ (\exists y. r(x, y) \wedge r(z, y))))))))$$

Exercise 8

Exercise. Consider *Adler's Hypergraph*:

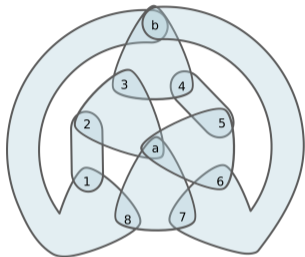

Play the marshals & robber game on this graph.

1. Can one marshal catch the robber?
 2. Can two marshals catch the robber?
 3. Can three marshals catch the robber?
 4. Adler et al. [Eur. J. Comb., 2007] proposed this graph as an example where fewer marshals can win if they are allowed to play non-monotonically, that is, if they are not required to shrink the remaining space in each turn. Can you confirm her findings?
- (*) Can you explain why non-monotone play is unavoidable in one of the above cases if the marshals want to win?

Exercise 8

Exercise. Consider *Adler's Hypergraph*:

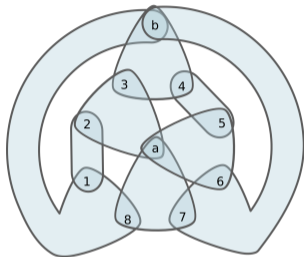

Solution.

Play the marshals & robber game on this graph.

1. Can one marshal catch the robber?
 2. Can two marshals catch the robber?
 3. Can three marshals catch the robber?
 4. Adler et al. [Eur. J. Comb., 2007] proposed this graph as an example where fewer marshals can win if they are allowed to play non-monotonically, that is, if they are not required to shrink the remaining space in each turn. Can you confirm her findings?
- (*) Can you explain why non-monotone play is unavoidable in one of the above cases if the marshals want to win?

Exercise 8

Exercise. Consider *Adler's Hypergraph*:

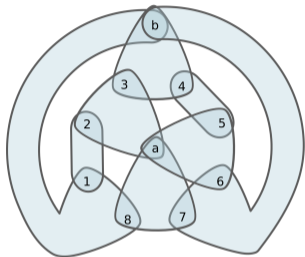

Solution.

1. No.

Play the marshals & robber game on this graph.

1. Can one marshal catch the robber?
 2. Can two marshals catch the robber?
 3. Can three marshals catch the robber?
 4. Adler et al. [Eur. J. Comb., 2007] proposed this graph as an example where fewer marshals can win if they are allowed to play non-monotonically, that is, if they are not required to shrink the remaining space in each turn. Can you confirm her findings?
- (*) Can you explain why non-monotone play is unavoidable in one of the above cases if the marshals want to win?

Exercise 8

Exercise. Consider *Adler's Hypergraph*:

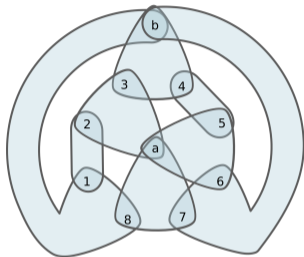

Solution.

1. No.
2. Yes, but only non-monotonically.

Play the marshals & robber game on this graph.

1. Can one marshal catch the robber?
 2. Can two marshals catch the robber?
 3. Can three marshals catch the robber?
 4. Adler et al. [Eur. J. Comb., 2007] proposed this graph as an example where fewer marshals can win if they are allowed to play non-monotonically, that is, if they are not required to shrink the remaining space in each turn. Can you confirm her findings?
- (*) Can you explain why non-monotone play is unavoidable in one of the above cases if the marshals want to win?

Exercise 8

Exercise. Consider *Adler's Hypergraph*:

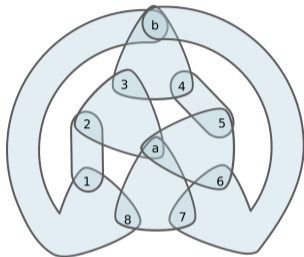

Solution.

1. No.
2. Yes, but only non-monotonically.
3. Yes, even when playing monotonically.

Play the marshals & robber game on this graph.

1. Can one marshal catch the robber?
 2. Can two marshals catch the robber?
 3. Can three marshals catch the robber?
 4. Adler et al. [Eur. J. Comb., 2007] proposed this graph as an example where fewer marshals can win if they are allowed to play non-monotonically, that is, if they are not required to shrink the remaining space in each turn. Can you confirm her findings?
- (*) Can you explain why non-monotone play is unavoidable in one of the above cases if the marshals want to win?

Exercise 8

Exercise. Consider *Adler's Hypergraph*:

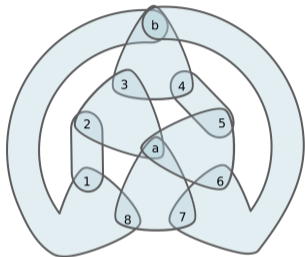

Solution.

1. No.
2. Yes, but only non-monotonically.
3. Yes, even when playing monotonically.
- (*) The graph has hypertree width 3, but generalised hypertree width 2.

Play the marshals & robber game on this graph.

1. Can one marshal catch the robber?
2. Can two marshals catch the robber?
3. Can three marshals catch the robber?
4. Adler et al. [Eur. J. Comb., 2007] proposed this graph as an example where fewer marshals can win if they are allowed to play non-monotonically, that is, if they are not required to shrink the remaining space in each turn. Can you confirm her findings?
- (*) Can you explain why non-monotone play is unavoidable in one of the above cases if the marshals want to win?